

OPERATING INSTRUCTIONS

Personal Computer

Model No. **CF-D1G** series

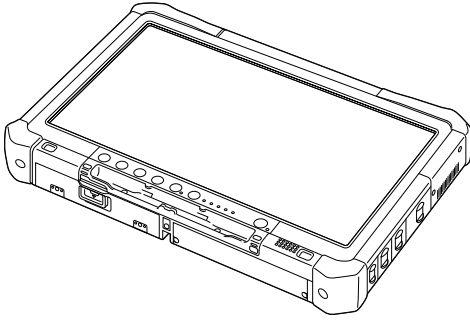

Contents

Getting Started

Introduction.....	2
Description of Parts	4
First-time Operation.....	7
Turning On / Turning Off.....	12

Getting Started

Useful Information

Handling and Maintenance.....	13
Installing Software	15

Useful Information

Troubleshooting

Troubleshooting (Basic).....	19
------------------------------	----

Troubleshooting

Appendix

LIMITED USE LICENSE AGREEMENT.....	23
Specifications	24

Appendix

Introduction







Thank you for purchasing this Panasonic product. For optimum performance and safety, please read these instructions carefully.

In these instructions, the names are referred as follows.

Windows 8.1 indicates Windows® 8.1 Operating System.

Windows 7 indicates Windows® 7 Operating System.

■ Terms and illustrations in these instructions

CAUTION :	Conditions that may result in minor or moderate injury.
NOTE :	Useful and helpful information.
Windows 8.1 Display “Charm”:	Align the cursor to the top right (or bottom right) corner of the screen to display Charm menu. Alternatively, flick toward the center of the screen from the right edge.
 -  :	Touch  (Settings) and then touch  (Power).
Windows 7  (Start) - [All Programs] :	Touch  (Start), and then touch [All Programs]. You may need to double-touch in some cases.
→ :	Page in these Operating Instructions or in the Reference Manual.
 :	Reference to the on-screen manuals.
Enter :	Press [Enter] key.
Ctrl + C :	Press and hold [Ctrl] key, and then press [C] key.
• The display of the key may be different from this manual according to the keyboard used. (e.g. “Delete” instead of “Del”)	

- Some illustrations are simplified to help your understanding and may look different from the actual unit.
- If you do not log on as an administrator, you cannot use some functions or cannot display some screens.
- Refer for the latest information about optional products to the catalogs, etc.
- In these instructions, the names and terms are referred as follows.
 - “Windows® 8.1 Pro 64-bit” as “Windows” or “Windows 8.1”
 - “Windows® 7 Professional 32-bit Service Pack 1” and “Windows® 7 Professional 64-bit Service Pack 1” as “Windows” or “Windows 7”
 - Circular media including DVD-ROM and CD-ROM as “discs”
 - DVD MULTI drive as “DVD drive”
 - “Multilingual User Interface” as “MUI”
- **Windows 8.1**
Screen messages are explained in [English (United States)].
(Depending on the language preference, some screen messages in these instructions are different from the actual screen messages. For example, [Flight mode] may be displayed instead of [Airplane mode] in some language preference.)

■ Disclaimer

Computer specifications and manuals are subject to change without notice. Panasonic Corporation assumes no liability for damage incurred directly or indirectly from errors, omissions or discrepancies between the computer and the manuals.

■ Trademarks

Microsoft®, Windows® and the Windows logo are registered trademarks of Microsoft Corporation of the United States and/or other countries.

Intel, Core, Centrino and PROSet are either registered trademarks or trademarks of Intel Corporation.

SDXC Logo is a trademark of SD-3C, LLC.



Adobe, the Adobe logo and Adobe Reader are either registered trademarks or trademarks of Adobe Systems Incorporated in the United States and/or other countries.

Bluetooth® is a registered trademark owned by Bluetooth SIG, Inc., U.S.A. and licensed to Panasonic Corporation.

Names of products, brands, etc., appearing in this manual are trademarks or registered trademarks of their respective own companies.

■ On-screen Manual

For further information about the computer, you can refer to the on-screen manual.

● Reference Manual

The Reference Manual contains the practical information to help you fully enjoy the computer's performance.

● Important Battery Tips

The Important Battery Tips will provide you with the battery information so that you can use the battery in the optimum condition to obtain longer operation time.

To access the on-screen manuals, follow the steps below.

Windows 8.1

On the Start screen, touch the [Manual Selector] tile, and select the on-screen manual.

Windows 7

Double-touch [Manual Selector] on the desktop screen, and select the on-screen manual.

Description of Parts

Front side

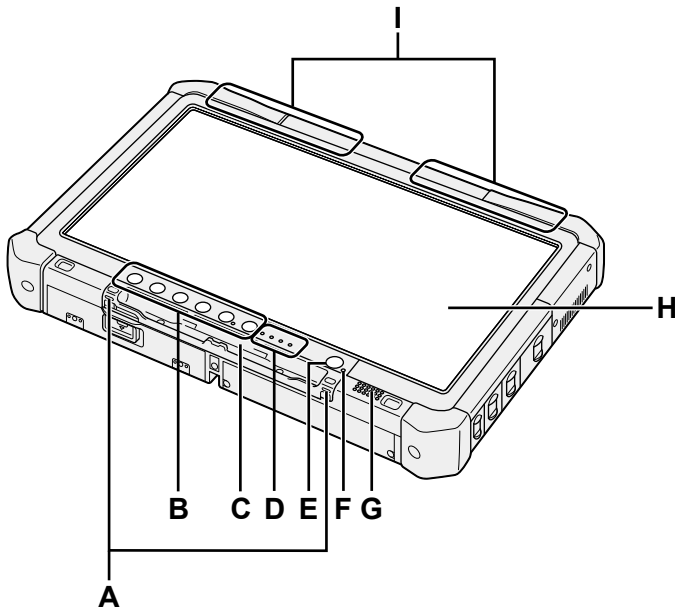

Bottom and rear side

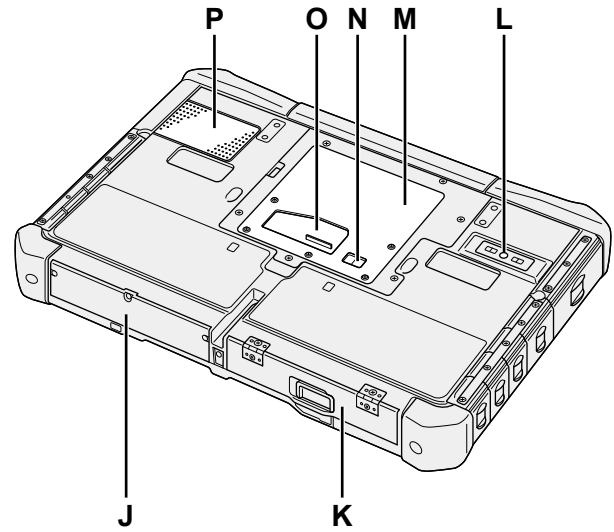

A: Tether Hooks

The tether hooks are not provided for some models.

B: Tablet Buttons

→ Reference Manual "Tablet Buttons"

C: Pen Holder

D: LED Indicator

: Battery status

→ Reference Manual "Battery Power"

: Wireless ready

This indicator lights when wireless LAN, Bluetooth, and/or Wireless WAN are connected and ready. It does not necessarily indicate the On/Off condition of the wireless connection.

→ Reference Manual "Wireless LAN", "Bluetooth", "Wireless WAN", "Disabling/Enabling Wireless Communication"

: Drive status

: SD Memory Card Indicator (Blinking: During access)

→ Reference Manual "SD Memory Card"

E: Power Switch

F: Power Status

(Off: Power off/Hibernation, Green: Power on, Blinking green: Sleep, Blinking green rapidly: Cannot power on or resume due to low temperature.)

G: Speaker

→ Reference Manual "Dashboard for Panasonic PC"

H: LCD

→ Reference Manual "Screen Input Operation"

I: Bluetooth Antenna

<Only for model with Bluetooth>

→ Reference Manual "Bluetooth"

Wireless WAN Antenna

<Only for model with wireless WAN>

→ Reference Manual "Wireless WAN"

Wireless LAN Antenna

<Only for model with wireless LAN>

→ Reference Manual "Wireless LAN"

J: Hard Disk Drive

K: Battery Pack

→ Reference Manual "Battery Power"

L: Rear Camera

<Only for model with rear camera>

→ Reference Manual "Camera"

M: RAM Module Slot

→ Reference Manual "RAM Module"

N: External Antenna Connector

O: Expansion Bus Connector

→ Reference Manual "Cradle"

P: Ventilation Hole (Intake)

Right side

Parts (F) illustrated below are all optional.

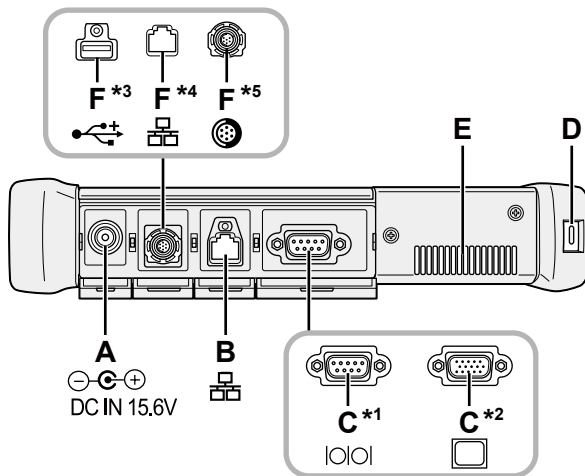

A: DC-IN Jack

B: LAN Port

→ *Reference Manual* "LAN"

C: Serial Port¹ / VGA Port²

¹ <Only for model with serial port>

² <Only for model with VGA port>

→ *Reference Manual* "External Display"

D: Security Lock

A Kensington cable can be connected.

For further information, read the manual that comes with the cable.

E: Ventilation Hole (Exhaust)

F: 4th USB Port (USB2.0)³ / 2nd LAN Port⁴ / Rugged USB2.0 Port⁶

³ <Only for model with 4th USB port (USB2.0)>

→ *Reference Manual* "USB Devices"

⁴ <Only for model with 2nd LAN port>

→ *Reference Manual* "LAN"

⁶ <Only for model with rugged USB2.0 port>

→ *Reference Manual* "USB Devices"

G: Wireless Switch

→ *Reference Manual* "Disabling / Enabling Wireless Communication"

H: ExpressCard Slot

→ *Reference Manual* "PC Card / ExpressCard"

I: SD Memory Card Slot

Keep SD Memory Cards away from infants and small children.

→ *Reference Manual* "SD Memory Card"

Left side

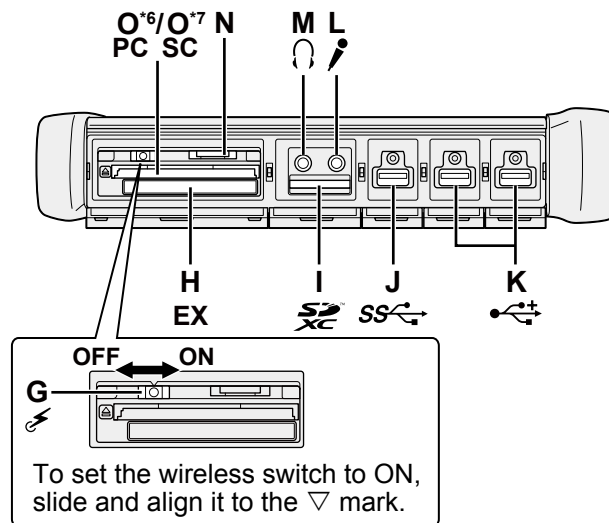

J: USB3.0 Port

→ *Reference Manual* "USB Devices"

K: USB2.0 Ports

→ *Reference Manual* "USB Devices"

L: Microphone Jack

A condenser microphone can be used. If other types of microphones are used, audio input may not be possible, or malfunctions may occur as a result.

M: Headphone Jack

You can connect headphones or amplified speakers. When they are connected, audio from the internal speakers is not heard.

N: SIM Card Slot

<Only for model with wireless WAN>

Insert the SIM card into the SIM card slot with the contact side facing downward and with the cut corner oriented forward.

→ *Reference Manual* "Wireless WAN"

CAUTION

● The slot accepts SIM Cards (15 mm x 25 mm).

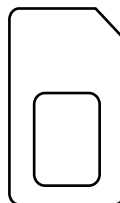

O: PC Card Slot⁷ / Smart Card Slot⁸

⁶ <Only for model with PC Card slot>

→ *Reference Manual* "PC Card / ExpressCard"

⁷ <Only for model with Smart Card slot>

→ *Reference Manual* "Smart Card"

Description of Parts

- This computer contains a magnet and magnetic products at the location circled in the illustration at right. Avoid leaving metallic object or magnetic media in contact with this area.

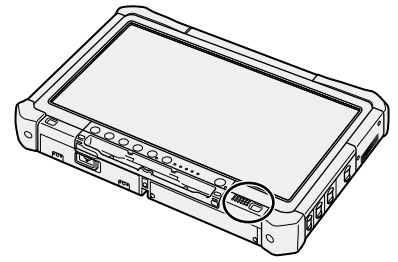

■ Attaching the stylus to the computer <Only for model with tether>

The tether prevents the stylus (included) from falling accidentally. Use the tether to attach the stylus to the computer so you will not lose it. There are holes (A) to attach it.

- ① Pass one of the loops through the hole.
- ② Pass the second loop on the tether through the first one.
- ③ Thread the second loop through the hole (A).
- ④ Pass the stylus through the second loop.

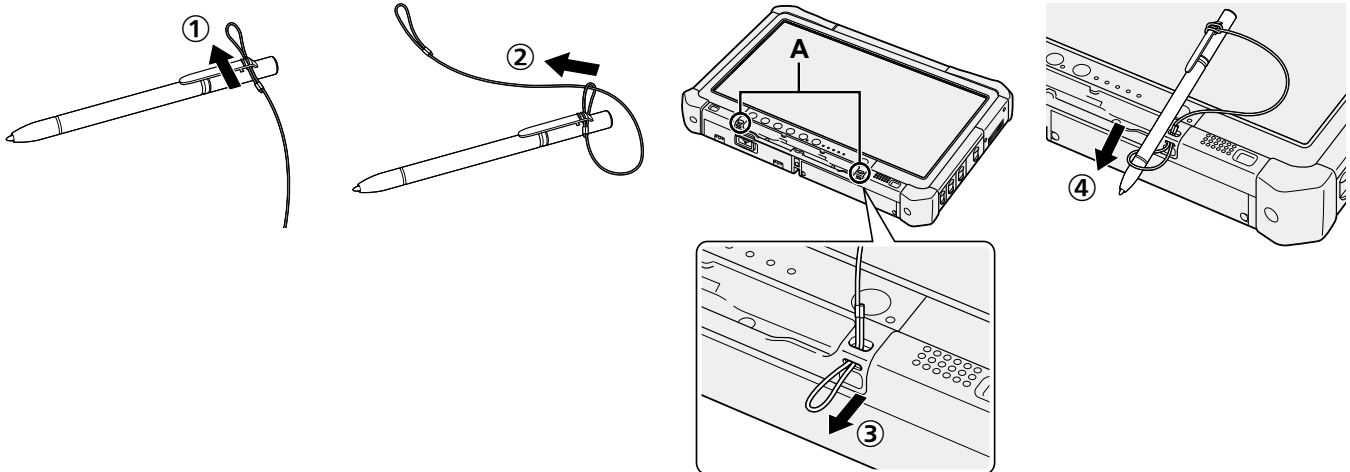

First-time Operation

■ Preparation

① Check and identify the supplied accessories.

If you do not find the described accessories, contact Panasonic Technical Support.

- AC Adaptor 1
- AC Cord 1
- Battery Pack 1

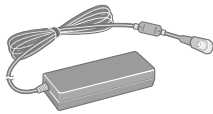

Model No: CF-AA5713A

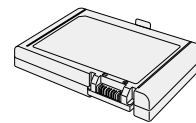

Model No: CF-VZSU73U / CF-VZSU73SP

- Soft Cloth 1



- Stylus 1

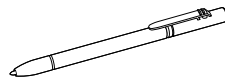

Some models may be supplied with a stylus different from the above.

- Tether 1



Some models may not be supplied with a tether, or supplied with a tether different from the above.

(→ Reference Manual "Screen Input Operation")

- Safety Precautions / Regulatory Information 1

• Depending on the model, the following items are supplied.

- OPERATING INSTRUCTIONS (CD-ROM) 1

② Read the LIMITED USE LICENSE AGREEMENT before breaking the seal on the computer's packaging (→ page 23).

■ Inserting the Battery Pack

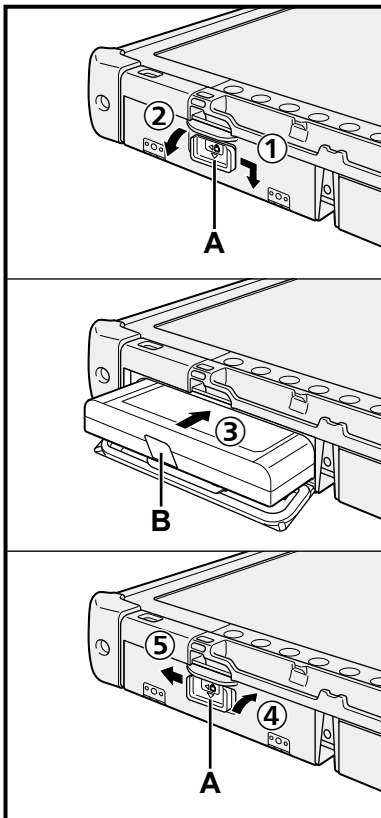

- ① Slide the latch (A) in the direction of the arrow.
- ② Open the cover.
- ③ Insert the battery pack until it securely fits the connector.
- ④ Close the cover until it clicks.
- ⑤ Slide the latch (A) in the direction of the arrow.

■ To remove the battery pack

In step ③ above, pull the tab (B) of the battery pack.

CAUTION

- Make sure the latch is securely locked. Otherwise the battery pack may fall when you carry the computer.

NOTE

- Note that the computer consumes electricity even when the computer power is off. If the battery pack is fully charged, the battery will fully discharge in the following period of time:
 - When power is off: Approx. 9 weeks
 - In sleep: Approx. 4 days
 - In hibernation: Approx. 8 days
- When the DC plug is not connected to the computer, disconnect the AC cord from your AC wall outlet. Power is consumed simply by having the AC adaptor plugged into an electrical outlet.

First-time Operation

1 Inserting the Battery Pack (→ page 7).

- Do not touch the terminals of the battery pack and the computer. Doing so can make the terminals dirty or damaged, and may cause malfunction of the battery pack and the computer.
- Be sure to attach the cover for use.

2 Attaching the stylus to the computer (→ page 6).

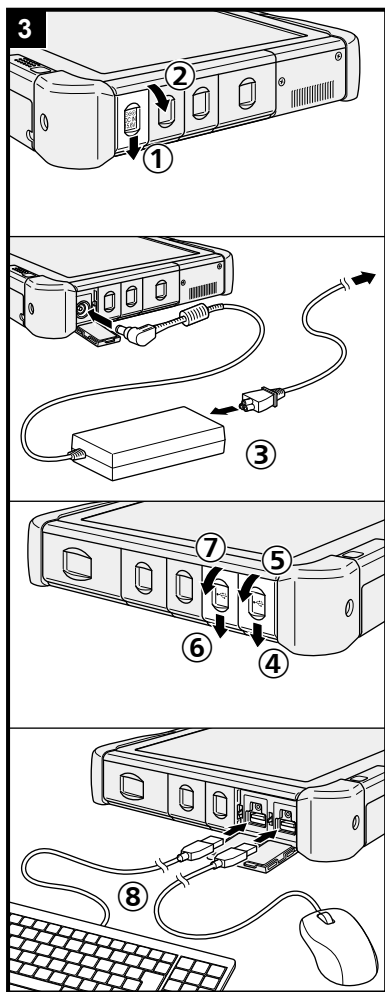

3 Connect your computer to a power outlet, and connect the external keyboard and mouse to the USB ports.

- ① Slide the latch in the direction of the arrow.
- ② Open the cover.
- ③ Connect the AC adaptor.
The battery charging starts automatically.
- ④ Slide the latch of one of the three USB ports in the direction of the arrow.
- ⑤ Open the cover.
- ⑥ Slide the latch of another USB port in the direction of the arrow.
- ⑦ Open the cover.
- ⑧ Connect the external keyboard and mouse to the USB ports.

CAUTION

- Do not disconnect the AC adaptor and do not switch the wireless switch to on until the first-time operation procedure is completed.
- When using the computer for the first time, do not connect any peripheral device (including wired LAN cable) except the battery pack, AC adaptor, external keyboard and mouse.
- **Handling the AC adaptor**
 - Problems such as sudden voltage drops may arise during periods of thunder and lightning. Since this could adversely affect your computer, an uninterruptible power source (UPS) is highly recommended unless running from the battery pack alone.

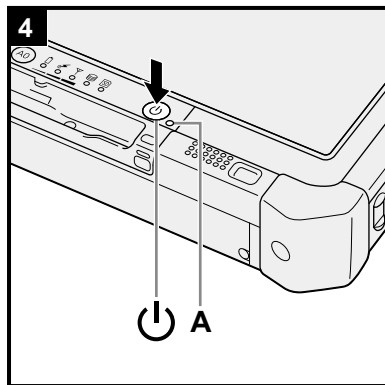

4 Turn on the computer.

- ① Confirm the wireless switch (→ page 5) is OFF.
- ② Press and hold the power switch  until the power indicator (A) lights.

CAUTION

- Do not press the power switch repeatedly.
- The computer will forcibly be turned off if you press and hold the power switch for 4 seconds or longer.
- Any changes from the default setting of the Setup Utility must not be made until the First-time Operation is completed.

Windows 7

5 Select language and OS (32 bit or 64 bit).

CAUTION

- Carefully choose your language because you cannot change it later. If you set a wrong language, you need to reinstall Windows.

NOTE

- You can operate with the Tablet Buttons. Follow the instructions displayed on the screen.

- ① Select language and OS (32bit or 64bit) and click [OK].
The language setting will start by clicking [OK] on the confirmation screen. You can return to the “Select Language” screen by clicking [Cancel].
The language and OS setting will be completed in about 15 minutes.
- ② When termination screen is displayed, click [OK] to turn off the computer.

6 Setup Windows.

Windows 8.1

Select language and touch [Next].

Windows 7

Turn on the computer.

Follow the on-screen instructions.

- The computer restarts several times. Do not touch the touchscreen, external keyboard or external mouse, and wait until the drive indicator  has turned off.
- After the computer is turned on, the screen remains black or unchanged for a while. This is not a malfunction. Wait for a moment until the Windows setup screen appears.
- During setup of Windows, use the touchscreen, external mouse, external keyboard and clicking to move the cursor and to click an item.
- Setup of Windows will take approximately **Windows 8.1** 5 minutes / **Windows 7** 20 minutes.
Go to the next step, confirming each message on the display.
- You can set the Wireless Network after the setup of Windows is complete.
Windows 8.1 If “Get online” is displayed, select “Skip this step”.
Windows 7 “Join a wireless network” screen may not appear.
- **Windows 8.1** Verify the time zone, date and time.

CAUTION

- Wait until the drive indicator  has turned off.
- You can change the user name, password, image and security setting after setup of Windows.
- Use standard characters as a computer name: numbers 0 through 9, uppercase and lowercase letters from A to Z, and the hyphen (-) character. If the error message “The computer name is not valid” appears, check if characters other than the above are not entered. If the error message still remains on the display, set the key entry mode to English (“EN”) and enter characters.
- Do not use the following words for user name: CON, PRN, AUX, CLOCK\$, NUL, COM1 to COM9, LPT1 to LPT9, @, &, space. In particular, if you create a user name (account name) that includes the “@” mark, a password will be requested at the screen, even if no password has been set. If you try to **Windows 8.1** sign in / **Windows 7** log on without entering a password, “The user name or password is incorrect.” may be displayed and you will not be able to **Windows 8.1** sign in / **Windows 7** log on to Windows (→ page 21).
- The wallpaper for the first logon user has already been set on “6 Setup Windows.”. When using this computer under the Sun, the screen becomes easily viewable by changing the wallpaper to the white wallpaper.
 - ① Long-touch on the desktop, and touch [Personalize] - [Desktop Background].
 - ② Select [Solid Colors] at [Picture Location].
 - ③ Select the white wallpaper and touch [Save changes].

7 Create the recovery disc.

A recovery disc allows you to install OS and restore its factory default condition, in case, for example, the recovery partition of the HDD is damaged. We recommend creating a recovery disc before you begin using the computer.

Refer to →  *Reference Manual* "Recovery Disc Creation Utility" about creating the disc.

NOTE

● PC Information Viewer

This computer periodically records the management information of the hard disk, etc. The maximum data volume for each record is 1024 bytes. This information is only used for estimating the cause in the case when the hard disk goes down by any possibility. They are never sent to outside via network nor used for any other purpose except for the purpose described the above.

To disable the function, add the check mark for [Disable the automatic save function for management information history] in [Hard Disk Status] of PC Information Viewer, and touch [OK]. Then follow the on-screen instructions.

(→  *Reference Manual* "Checking the Computer's Usage Status")

● Windows 8.1

In the default settings, a shortcut icon for Korean language is on the Desktop screen. You may delete the icon if not necessary.

● Windows 7

If the recovery partition is deleted, you cannot create Recovery Disc(s).

■ Before using wireless function

① Slide the wireless switch to ON.

Windows 8.1

② Display "Charm", and touch  - [Change PC Settings] - [Network] - [Airplane mode].

Set [Airplane mode] to [Off], and then;

set [Wi-Fi] to [On] (for wireless LAN).

set [Mobile broadband] to [On] (for wireless WAN).

set [GPS] to [On] (for wireless WAN).

set [Bluetooth] to [On] (for Bluetooth).

■ To change the partition structure

You can shrink a part of an existing partition to create unallocated disk space, from which you can create a new partition. In the default setting, you can use a single partition.

① Windows 8.1

1. Flick from the middle of the Start screen to the top, and then long-touch [This PC] under "Windows System".

2. Touch [Manage] on app bar.

Windows 7

Touch  (Start) and long touch [Computer], then touch [Manage].

● A standard user needs to enter an administrator password.

② Touch [Disk Management].

③ Long-touch the partition for Windows ("c" drive in the default setting), and touch [Shrink Volume].

● The partition size depends on the computer specifications.

④ Input the size in [Enter the amount of space to shrink in MB] and touch [Shrink].

● You cannot input a larger number than the displayed size.

● To select [Reinstall to the OS related partitions.] in reinstalling OS (→ page 16), 70 GB or more is necessary for [Total size after shrink in MB].

⑤ Long-touch [Unallocated] (the shrunk space in the step ④) and touch [New Simple Volume].

⑥ Follow the on-screen instructions to make the settings, and touch [Finish].

Wait until formatting is completed.

NOTE

● You can create an additional partition using remaining unallocated space or newly creating unallocated space.

● To delete a partition, long-touch the partition and touch [Delete Volume] in step ③.



■ **Windows 8.1** To select language

To select a language other than the one you have selected during the first-time operation, follow the steps below.

- ① Flick from the middle of the Start screen to the top, and then touch [Control Panel] under “Windows System”.
- ② Touch [Clock, Language, and Region] - [Language] - [Add a language].
- ③ Select a language, and then touch [Add].
Depending on the region, two or more languages are selectable. Touch [Open] and select the desired language, and then touch [Add].
- ④ Touch [Options] for the language you want to use.
- ⑤ Touch [Make this the primary language].
- ⑥ Touch [Log off now].
- ⑦ Sign in to the Windows.

Turning On / Turning Off

Turning On

Press and hold the power switch  (→ page 4) until the power indicator  (→ page 4) lights.

NOTE

- Do not press the power switch repeatedly.
- The computer will forcibly be turned off if you press and hold the power switch for four seconds or longer.
- Once you turn off the computer, wait for ten seconds or more before you turn on the computer again.
- Do not perform the following operation until the drive indicator  turns off.
 - Connecting or disconnecting the AC adaptor
 - Pressing the power switch
 - Touching the tablet buttons, screen or external mouse
 - Turn on/off the wireless switch

Turning Off

- ① Shut down the computer.

Windows 8.1

1. Display “Charm”, and touch .
2. Touch [Power] - [Shut down].

Windows 7

Touch  (Start) - [Shutdown].

NOTE

- **Windows 8.1**
To turn off the computer completely, proceed as follows.
 - ① Display “Charm”, and touch  - [Change PC settings] - [Update and recovery] - [Recovery].
 - ② Touch [Restart now] under “Advanced startup”.
 - ③ Touch [Turn off your PC].

Precaution against Starting Up/Shutting Down

- Do not do the following
 - Connecting or disconnecting the AC adaptor
 - Pressing the power switch
 - Touching the tablet buttons, screen or external mouse
 - Turn on/off the wireless switch

NOTE

- To conserve power, the following power saving methods are set at the time of purchase.
 - The screen automatically turns off after :
 - 10 minutes (when AC adaptor is connected) of inactivity
 - 5 minutes (when operating on battery power) of inactivity
 - The computer automatically enters sleep^{*1} after :
 - 20 minutes (when AC adaptor is connected) of inactivity
 - 15 minutes (when operating on battery power) of inactivity
- ^{*1} Refer to  *Reference Manual* “Sleep or Hibernation Functions” about resuming from sleep.

Handling and Maintenance

Operation environment

- Place the computer on a flat stable surface not subject to shock, vibration, and danger of dropping. Do not place the computer upright or turn it over. If the computer is exposed to an extremely strong impact, it may become damaged.
 - Temperature: Operation : -10 °C to 50 °C {14 °F to 122 °F} (IEC60068-2-1, 2)^{*1}
Storage : -20 °C to 60 °C {-4 °F to 140 °F}
 - Humidity: Operation : 30 % to 80 % RH (No condensation)
Storage : 30 % to 90 % RH (No condensation)
- Even within the above temperature/humidity ranges, operation for a long time in an extreme environments, smoking nearby, or operation in places where oil is used or where there is a lot of dust will result in the product deterioration and will shorten the product life.
- ^{*1} Do not expose the skin to this product when using the product in a hot or cold environment. (→ “Safety Precautions / Regulatory Information”)
- If the computer is wet in temperatures of 0 °C {32 °F} or below, freeze damage may occur. Make sure to dry off the computer in such temperatures.
- Do not place the computer in the following areas, otherwise the computer may be damaged.
 - Near electronic equipment. Image distortion or noise may occur.
 - In extremely high or low temperature.
 - As the computer can become hot during operation, keep it away from items that are sensitive to heat.

Handling cautions

This computer is designed to minimize shock to parts such as the LCD and the hard disk drive, but no warranty is provided against any trouble caused by shock. Be extremely careful when handling the computer.

- When carrying the computer:
 - Turn off the computer.
 - Remove all external devices, cables, Express Cards and other protruding objects.
 - Do not drop or hit the computer against solid objects.
 - Do not grip the display part.
- When you board an airplane, take the computer with you and never put it in your checked luggage. When using the computer on airplane, follow the airline's instructions.
- When carrying a spare battery, put it in a plastic bag to protect its terminals.
- Use only the included stylus to touch the touchscreen. Do not place any object on its surface and do not press down strongly with sharp-pointed or hard objects that may leave marks (e.g., nails, pencils and ball point pens).
- Do not use the touchscreen when dust or dirt (e.g., oil) is on the screen. Otherwise foreign particles on the screen/stylus can scratch the screen surface or obstruct the stylus operation.
- Use the stylus only for touching the screen. Using it for any other purpose may damage the stylus and result in scratches on the screen.

■ When using peripheral devices

Follow these instructions and the Reference Manual to avoid any damage to the devices. Carefully read the instruction manuals of the peripheral devices.

- Use the peripheral devices conforming to the computer's specifications.
- Connect to the connectors in the correct direction.
- If it is hard to insert, do not try forcibly but check the connector's shape, direction, alignment of pins, etc.
- If screws are included, fasten them securely.
- Remove the cables when you carry the computer. Do not pull the cables forcibly.

■ Preventing your computer from unauthorized use via wireless LAN/Bluetooth/wireless WAN

<Only for model with wireless LAN/Bluetooth/wireless WAN>

- Before using wireless LAN/Bluetooth/wireless WAN, make the appropriate security settings such as data encryption.

■ Battery Recalibration

- The battery recalibration may take a long time due to the large battery capacity. This is not a malfunction.

<When performing “Battery Recalibration” after shutting down Windows>

- Full charge: Approximately 2.0 hours (Normal Temperature Mode)
 Approximately 3.5 hours (High Temperature Mode)
- Complete discharge: Approximately 3.0 to 4.5 hours (Normal Temperature Mode)
 Approximately 2.0 to 4.0 hours (High Temperature Mode)

When performing “Battery Recalibration” without shutting down Windows, it may take more time to charge / discharge.

Handling and Maintenance

■ PC-Diagnostic Utility

When you start the PC-Diagnostic Utility without connecting an external keyboard and an external mouse, shut down the computer by pressing and holding the power switch. Then, connect an external keyboard and an external mouse to the computer and restart the PC-Diagnostic Utility.

Maintenance

To clean the LCD panel

Use the soft cloth included with the computer. (For further information, refer to “Suggestions About Cleaning the LCD Surface”. →  *Reference Manual* “Screen Input Operation”)

To clean areas other than the LCD panel

Wipe with a soft dry cloth such as gauze. When using detergent, dip a soft cloth in water-diluted detergent and wring it thoroughly.

CAUTION

- Do not use benzene, thinner, or rubbing alcohol since it may adversely affect the surface causing discoloration, etc. Do not use commercially-available household cleaners and cosmetics, as they may contain components harmful to the surface.
- Do not apply water or detergent directly to the computer, since liquid may enter inside of the computer and cause malfunction or damage.

Installing Software

Installing software will return the computer to the default condition. When you install the software, the hard disk data will be erased.

Back up important data to other media or an external hard disk before installation.

CAUTION

- If the recovery partition is deleted, you cannot perform hard disk (flash memory) recovery.

To check the Recovery Partition, perform the following methods.

① Windows 8.1

1. Flick from the middle of the Start screen to the top, and then long-touch [This PC] under “Windows System”.
2. Touch [Manage] on the app bar.

Windows 7

Touch  (Start) and long-touch [Computer], then touch [Manage].

- A standard user needs to enter an administrator password.

- ② Touch [Disk Management].

■ Remove everything and reinstall Windows

Preparation

- Connect the external keyboard and the mouse.
- Remove all peripherals.
- Connect the AC adaptor and do not remove it until installation is complete.

Windows 8.1

1 Perform “Remove everything and reinstall Windows”.

- ① Display “Charm”, and touch  - [Change PC settings] - [Update and recovery] - [Recovery].
- ② Touch [Get Started] under “Remove everything and reinstall Windows”.
- ③ Touch [Next].
- ④ Select the option.

- Just remove my files

Perform the reinstallation of the Windows in a few moments (Approximately 20 minutes).

- Fully clean the drive

By fully cleaning, the deleted files can not be recovered easily and the security level will be increased. The processing time will be longer (Approximately 140 minutes).

Follow the on-screen instructions.

After the reinstallation, the computer will restart.

- Do not interrupt installation, for example by turning off the computer or performing other operation. Otherwise installation may become unavailable as Windows may not start up or the data may be corrupted.

2 Perform the “First-time Operation”, starting from step 6, “Setup Windows” (→ page 9).

NOTE

- The date and time, and the time zone may not be correct. Be sure to set them correctly.

3 Perform Windows Update.

4 <Only for model with TPM> Clear TPM.

- ① Flick from the middle of the Start screen to the top.
- ② Touch [Run] under “Windows System”, input [tpm.msc] and touch [OK].
- ③ Touch [Clear TPM...] under “Actions” on the right of the “TPM Manager on Local Computer” screen.
- ④ Touch [Restart] of the “Manage the TPM security hardware” screen.
The computer will restart.
- ⑤ When “TPM configuration change was requested to ...” is displayed, press **F12**.
- ⑥ Touch the Desktop tile, and when “TPM is ready” appears, touch [Close].

Installing Software

■ Hard disk (Flash memory) recovery

You can reinstall the OS that was pre-installed at the time of purchase (Windows 8.1 or Windows 7).

CAUTION

- If the recovery partition is deleted, you cannot perform hard disk (flash memory) recovery.

Preparation

- Connect the external keyboard and the mouse.
- Remove all peripherals.
- Connect the AC adaptor and do not remove it until installation is complete.

Windows 8.1 If reinstallation using the method described in “Remove everything and reinstall Windows” above is not successful, follow the steps below.

1 Start the Setup Utility.

Windows 8.1

- ① Display “Charm”, and touch  - [Change PC settings] - [Update and recovery] - [Recovery].
- ② Touch [Restart now] under “Advanced startup”.
- ③ Touch [Troubleshoot] - [Advanced options] - [UEFI Firmware Settings] - [Restart].

Windows 7

Turn on the computer, and touch [Click here for Setup] that appears at the top left corner of the screen while [Panasonic] boot screen is displayed.

- If the [Panasonic] boot screen is not displayed, as soon as the computer starts up, press  several times until the Setup Utility screen appears.
- If the password is requested, enter the Supervisor Password.

2 Write down all of the contents of the Setup Utility and double-touch [Load Default Values].

At the confirmation message, select [Yes] and press **Enter**.

3 Check the [UEFI Boot] setting of the Setup Utility.

[UEFI Boot] should be set to as follows.

When Windows 8.1 is used : [Enabled]

When Windows 7 is used : [Disabled]

4 Touch [Exit] and double-touch [Save Values and Reboot].

At the confirmation message, select [Yes] and press **Enter**.

Computer will restart.

5 Touch top left of the screen while [Panasonic] boot screen is displayed.

The Setup Utility starts up.

- If the password is requested, enter the Supervisor Password.

6 Touch [Exit] and double-touch [Recovery Partition].

7 Windows 8.1

Click [Next] and click [YES].

Windows 7

Click [Reinstall Windows] and click [Next].

8 At the License Agreement screen, click [Yes, I agree to the provisions above and wish to continue!] and click [Next].

9 Click [Next].

If the option is displayed, select the setting and click [Next].

- [Reinstall Windows to the System Disk to factory default.]
Select this option when you want to install Windows to the factory default. After installation, you can create a new partition. For how to create a new partition, refer to “To change the partition structure” (→ page 10).
- [Reinstall to the OS related partitions.]¹
Select this option when the hard disk has already been divided into several partitions and you want to keep the partition structure. For how to create a new partition, refer to “To change the partition structure” (→ page 10).

¹ This does not appear if Windows cannot be installed to the recovery partition and the area usable by Windows.

10 Windows 7 At the confirmation message, click [YES].

11 Windows 7

<For localized OS model>

Select OS (32bit or 64bit) and click [OK].

<For MUI OS model>

Select language and system type (32bit or 64bit) and click [OK].

At the confirmation message, click [OK].

To cancel the recovery procedure, click [CANCEL], and click the  mark that appears at the top right corner of the screen.

12 At the confirmation message, click [YES].

Installation starts according to the instructions on the screen. (It will take approximately 20 minutes.)

- Do not interrupt installation, for example by turning off the computer or performing other operation. Otherwise installation may become unavailable as Windows may not start up or the data may be corrupted.

13 When Ending process screen is displayed, click [OK] to turn off the computer.**14 Turn on the computer.**

- If the password is requested, enter the Supervisor Password.

15 Perform the “First-time Operation”, starting from step 6, “Setup Windows” (→ page 9).**NOTE**

- **Windows 8.1** The date and time, and the time zone may not be correct. Be sure to set them correctly.

16 Start the Setup Utility and change the settings as necessary.**17 Perform Windows Update.****18 **Windows 8.1** <Only for model with TPM> Clear TPM (→ page 15).****■ Using Recovery Disc**

Use the Recovery Disc in the following conditions.

- You have forgotten the administrator password.
- Installation is not complete. The recovery partition in the hard disk (flash memory drive) may be broken.
- The recovery partition is deleted.
- **Windows 7** <Only for Windows 7 downgrade model>
To change OS from Windows 7 to Windows 8.1, or vice versa.

NOTE

- **Windows 7** To change the OS from 32 bit to 64 bit or vice versa, the recovery partition must be used to install the OS. Therefore, the recovery partition must still exist on the hard disk in order to perform this operation.

Preparation

- Prepare the following items:
 - Recovery Disc (→  *Reference Manual* “Recovery Disc Creation Utility”)
 - USB DVD drive (optional) (refer to recent catalogs and other sources for information about the products available)
- Connect the external keyboard and the mouse.
- Remove all peripherals (except for the USB DVD drive).
- Connect the AC adaptor and do not remove it until installation is complete.

1 Connect the DVD drive to the USB port.**2 Start the Setup Utility.****Windows 8.1**

- ① Display “Charm”, and touch  - [Change PC settings] - [Update and recovery] - [Recovery].
- ② Touch [Restart now] under “Advanced startup”.
- ③ Touch [Troubleshoot] - [Advanced options] - [UEFI Firmware Settings] - [Restart].

Windows 7

Turn on the computer, and touch [Click here for Setup] that appears at the top left corner of the screen while [Panasonic] boot screen is displayed.

- If the [Panasonic] boot screen is not displayed, as soon as the computer starts up, press  several times until the Setup Utility screen appears.
- If the password is requested, enter the Supervisor Password.

3 Write down all of the contents of the Setup Utility and touch [Exit] and double-touch [Load Default Values].

At the confirmation message, select [Yes] and press **Enter**.

4 Check the [UEFI Boot] setting of the Setup Utility.

[UEFI Boot] should be set to as follows.

When the recovery disc for Windows 8.1 is used: [Enabled]

When the recovery disc for Windows 7 is used: [Disabled]

5 Set the Recovery Disc into the DVD drive.**6 Touch [Exit] and double-touch [Save Values and Reboot].**

At the confirmation message, select [Yes] and press **Enter**.

Computer will restart.

Installing Software

- 7 **Touch top left of the screen while [Panasonic] boot screen is displayed.**
The Setup Utility starts up.
 - If the password is requested, enter the Supervisor Password.
 - 8 **Touch [Exit] and double-touch your DVD drive in [Boot Override].**
The computer will restart.
 - 9 **Click [Reinstall Windows] and click [Next].**
 - 10 **Windows 8.1** At the confirmation message, click [YES].
 - 11 **At the License Agreement screen, click [Yes, I agree to the provisions above and wish to continue!] and click [Next].**
 - 12 **Windows 7** <For MUI OS model>
Click [Next].
If the option is displayed, select the setting and click [Next].
 - [Reinstall with HDD recovery partition.]
Standard recovery method.
You can use recovery from Recovery Partition.
 - [Reinstall without HDD recovery partition.]
Increase usable HDD size.
You can NOT use recovery from Recovery Partition.
When this option is selected, you can no longer create Recovery Disc(s) after the recovery operation.
-
- CAUTION**
- Carefully choose above item because you cannot change it later.
-
- 13 **Click [Next].**
If the option is displayed, select the setting and click [Next].
 - [Reinstall Windows to the System Disk to factory default.]
Select this option when you want to install Windows to the factory default. After installation, you can create a new partition. For how to create a new partition, refer to “To change the partition structure” (→ page 10).
 - [Reinstall to the OS related partitions.]²
Select this option when the hard disk has already been divided into several partitions. For how to create a new partition, refer to “To change the partition structure” (→ page 10).
You can keep the partition structure.
² This does not appear when [Reinstall without HDD recovery partition.] is selected, or if Windows cannot be installed to the recovery partition and the area usable by Windows.
 - 14 **At the confirmation message, click [YES].**
 - 15 **Windows 7** <For MUI OS model>
Select language and system type (32bit or 64bit) and click [OK].
At the confirmation message, click [OK].
To cancel the recovery procedure, click [CANCEL], and click the  mark that appears at the top right corner of the screen.
Windows 8.1 / **Windows 7**
Installation starts according to the instructions on the screen. (It will take approximately 30 - 45 minutes. The process may take longer depending on the type of the DVD drive used.)
 - Do not interrupt installation, for example by turning off the computer.
Otherwise installation may become unavailable as Windows may not start up or the data may be corrupted.
 - 16 **When Ending process screen is displayed, remove the Recovery Disc and DVD Drive and then click [OK].**
Follow the on-screen instructions.
Some models may take approximately 40 minutes.
 - 17 **Perform the “First-time Operation”, starting from step 6, “Setup Windows” (→ page 9).**
-
- NOTE**
- **Windows 8.1** The date and time, and the time zone may not be correct. Be sure to set them correctly.
-
- 18 **Start the Setup Utility and change the settings as necessary.**
 - 19 **Perform Windows Update.**
 - 20 **Windows 8.1** <Only for model with TPM> **Clear TPM (→ page 15).**

Troubleshooting (Basic)





Follow the instructions below when a problem has occurred. There is also an advanced troubleshooting guide in the "Reference Manual". For a software problem, refer to the software's instruction manual. If the problem persists, contact Panasonic Technical Support. You can also check the computer's status in the PC Information Viewer (→  *Reference Manual* "Checking the Computer's Usage Status").

■ Starting Up



<p>Cannot start up. The power indicator or battery indicator is not lit.</p>	<ul style="list-style-type: none"> ● Connect the AC adaptor. ● Insert a fully charged battery. ● Remove the battery pack and the AC adaptor, then connect them again. ● Even if the AC adaptor and battery pack are correctly connected, if the battery indicator is not lit, the AC adaptor protection function may be operating. Disconnect the AC cord, wait three minutes or more, and reconnect the AC cord. ● If a device is connected to the USB port, disconnect the device, or set [USB Port] or [Legacy USB Support] to [Disabled] in the [Advanced] menu of the Setup Utility. ● If a device is connected to the ExpressCard slot, disconnect the device, or set [ExpressCard Slot] to [Disabled] in the [Advanced] menu of the Setup Utility. ● Check the [UEFI Boot] setting of the Setup Utility. [UEFI Boot] should be set to Windows 8.1 [Enabled] / Windows 7 [Disabled].
<p>The power is turned on but "Warming up the system" appears.</p>	<ul style="list-style-type: none"> ● The computer is warming up before start up. Wait for the computer to start up (takes up to 30 minutes). If, "Cannot warm up the system" is displayed, the computer failed to warm up and does not start. In this case, turn off the computer, leave it in an environment of 5 °C or higher temperature for about an hour, and then turn on the power again.
<p>Cannot turn on the computer. The computer does not resume from sleep. (The power indicator blinks quickly in green.)</p>	<ul style="list-style-type: none"> ● Leave it in an environment of 5 °C or higher temperature for about an hour, then turn on the power again.
<p>After adding or changing the RAM module, the power is turned on but nothing is displayed on the screen.</p>	<ul style="list-style-type: none"> ● Turn off the computer and remove the RAM module, then confirm whether the RAM module has conformed to specification. When the RAM module has conformed to specification, install it again.
<p>It takes time for the power indicator to light up.</p>	<ul style="list-style-type: none"> ● If the power switch is pressed immediately after the battery pack has been mounted on the computer, and while the AC adaptor is not connected, it may take about five seconds before the power indicator lights up and the computer turns on. This is because the computer is checking the remaining battery charge; it is not a malfunction.
<p>You have forgotten the password.</p>	<ul style="list-style-type: none"> ● Supervisor Password or User Password: Contact Panasonic Technical Support. ● Administrator password: <ul style="list-style-type: none"> • If you have a password reset disk, you can reset the administrator password. Set the disk and enter any wrong password, then follow the on-screen instructions and set a new password. • If you do not have a password reset disk, reinstall (→ page 15) and set up Windows, and then set a new password.
<p>"Remove disks or other media. Press any key to restart" or a similar message appears.</p>	<ul style="list-style-type: none"> ● A floppy disk in the drive or USB memory is connected, and it does not contain system startup information. Remove the floppy disk and USB memory, connect an external keyboard and then press any key. ● If a device is connected to the USB port, disconnect the device, or set [USB Port] or [Legacy USB Support] to [Disabled] in the [Advanced] menu of the Setup Utility. ● If a device is connected to the ExpressCard slot, disconnect the device, or set [ExpressCard Slot] to [Disabled] in the [Advanced] menu of the Setup Utility. ● <Only for model with ExpressCard slot> If the problem persists after removing the disk, it may be a hard disk failure. Contact Panasonic Technical Support.
<p>Windows startup and operation is slow.</p>	<ul style="list-style-type: none"> ● Start the Setup Utility (→  <i>Reference Manual</i> "Setup Utility") to return the Setup Utility settings (excluding the passwords) to the default values. Start the Setup Utility and make the settings again. (Note that the processing speed depends on the application software, so this procedure may not make Windows faster.) ● If you installed a resident software after purchase, turn off the residence.

Troubleshooting (Basic)

■ Starting Up

<p>The date and time are incorrect</p>	<ul style="list-style-type: none"> ● Make the correct settings. <ol style="list-style-type: none"> ① Open the Control Panel. <ul style="list-style-type: none"> Windows 8.1 Flick from the middle of the Start screen to the top and touch [Control Panel] under “Windows System”. Windows 7 Touch  (Start) - [Control Panel]. ② Touch [Clock, Language, and Region] - [Date and Time]. ● If the problem persists, the internal clock battery may need to be replaced. Contact Panasonic Technical Support. ● When the computer is connected to LAN, check the date and time of the server. ● The 2100 A.D. or later year will not be correctly recognized on this computer.
<p>[Executing Battery Recalibration] screen appears.</p>	<ul style="list-style-type: none"> ● The Battery Recalibration was canceled before Windows was shut down last time. To start up Windows, turn off the computer by the power switch, and then turn on.
<p>[Enter Password] does not appear when resuming from sleep/hibernation.</p>	<ul style="list-style-type: none"> ● Select [Enabled] in [Password On Resume] in the [Security] menu of the Setup Utility (→  <i>Reference Manual</i> “Setup Utility”). ● The Windows password can be used instead of the password set in the Setup Utility. <ol style="list-style-type: none"> ① Add a password. <ul style="list-style-type: none"> Windows 8.1 <ol style="list-style-type: none"> 1. Display “Charm” and touch  - [Change PC settings] - [Accounts]. 2. Touch [Sign-in options], and touch [Add] under “Password”. Windows 7 <ol style="list-style-type: none"> 1. Touch  (Start) - [Control Panel]. 2. Touch [User Accounts and Family Safety] - [Add or remove user accounts]. ② Set up the following. <ul style="list-style-type: none"> Windows 8.1 <ol style="list-style-type: none"> 1. Open the Control Panel, touch [System and Security] - [Power Options] - [Require a password on wakeup]. 2. Add a check mark for [Require a password]. Windows 7 <ol style="list-style-type: none"> 1. Touch [Control Panel] - [System and Security] - [Power Option] - [Require a password when the computer wakes] and add a check mark for [Require a password].
<p>Cannot resume.</p>	<ul style="list-style-type: none"> ● An error may occur when the computer automatically enters the sleep or hibernation mode while the screen saver is active. In this case, turn off the screen saver or change the pattern of the screen saver.

Starting Up

Other startup problems.	<ul style="list-style-type: none"> ● Start the Setup Utility (→  <i>Reference Manual</i> “Setup Utility”) to return the Setup Utility settings (excluding the passwords) to the default values. Start the Setup Utility and make the settings again. ● Remove all peripheral devices. ● Check to see if there was a disk error. <ol style="list-style-type: none"> ① Remove all peripheral devices including an external display. ② Windows 8.1 Flick from the middle of the Start screen to the top, and then long-touch [This PC] under “Windows System”. Windows 7 Touch  (Start) - [Computer]. ③ Windows 8.1 Long-touch [Windows (C:)], and touch [Properties]. Windows 7 Long-touch [Local Disk (C:)], and touch [Properties]. ④ Windows 8.1 Touch [Tools] - [Check]. Windows 7 Touch [Tools] - [Check Now...]. <ul style="list-style-type: none"> • A standard user needs to enter an administrator password. ⑤ Follow the on-screen instructions. ● Windows 7 Connect the external keyboard to the computer, and start it in Safe Mode and check the error details. When the [Panasonic] boot screen disappears^{*1} at startup, press and hold F8 until the Windows Advanced Options Menu is displayed. Select the Safe Mode and press Enter. <p>^{*1} When [Password on boot] is set to [Enabled] or [Auto] in the [Security] menu of the Setup Utility, [Enter Password] appears after the [Panasonic] boot screen disappears. As soon as you enter the password and press Enter, press and hold F8.</p>
-------------------------	---

Entering Password

Cannot log on to Windows. (“The user name or password is incorrect.” is displayed.)	<ul style="list-style-type: none"> ● The user name (account name) includes an “@” mark. <ul style="list-style-type: none"> - If another user account name exists: Log on to Windows using another user account name and delete the account name that includes “@”. Then create a new account name. - If no other account name exists: You need to reinstall Windows (→ page 15).
---	--

Shutting down

Windows does not shut down.	<ul style="list-style-type: none"> ● Remove the USB device and the ExpressCard. ● Wait one or two minutes. It is not a malfunction.
-----------------------------	---

Display

No display.	<ul style="list-style-type: none"> ● <Only for model with VGA port> The external display is selected. Change the display output destination. ● <Only for model with VGA port> When using an external display, <ul style="list-style-type: none"> • Check the cable connection. • Turn on the display. • Check the settings of external display. ● The display is turned off by the power-saving function. To resume, touch the screen. ● The computer entered sleep or hibernation by the power-saving function. To resume, press the power switch.
The screen is dark.	<ul style="list-style-type: none"> ● The screen might be darker when the AC adaptor is not connected. Adjust the brightness by using Dashboard for Panasonic PC. As you increase the brightness, battery consumption increases. You can separately set the brightness for when the AC adaptor is connected and when not connected.

Troubleshooting (Basic)

■ Display

The screen is disordered.	<ul style="list-style-type: none"> ● Changing the number of display colors and resolution may affect the screen. Restart the computer. ● Connecting/disconnecting an external display may affect the screen. Restart the computer. ● Resuming from sleep or hibernation may affect the screen of the external display. Restart the computer.
<Only for model with VGA port> During Simultaneous display, one of the screens becomes disordered.	<ul style="list-style-type: none"> ● When using the Extended Desktop, use the same display colors for the external display as those used by the LCD. If you continue to experience problems, try changing the display. <ol style="list-style-type: none"> ① Long-touch on the desktop, and touch [Graphics Properties]. ● Simultaneous display cannot be used until Windows startup is complete (during Setup Utility, etc.).
<Only for model with VGA port> The external display does not work normally.	<ul style="list-style-type: none"> ● If the external display does not support the power saving function, it may not work normally when the computer enters the power saving mode. Turn off the external display.



■ Touchscreen

The cursor does not work.	<ul style="list-style-type: none"> ● When using the external mouse, connect it correctly. ● Restart the computer using the external keyboard. ● If the computer does not respond to the external keyboard commands, read “No response” (→ below).
Cannot input using the touchscreen.	<ul style="list-style-type: none"> ● Set [Touchscreen Mode] to [Auto] or [Tablet Mode] in the [Main] menu of the Setup Utility.
Cannot point the correct position using the included stylus.	<ul style="list-style-type: none"> ● Perform the touchscreen calibration. (→  Reference Manual “Screen Input Operation”)

■ On-screen Document

Windows 7 The document of PDF format is not displayed.	<ul style="list-style-type: none"> ● Install Adobe Reader. <ol style="list-style-type: none"> ① Log on to Windows as an administrator. ② Touch  (Start) and input “c:\util\reader\Pinstall.bat” in [Search programs and files], then press Enter. ③ Update Adobe Reader to its latest version. If your computer is connected to the internet, start up Adobe Reader and touch [Help] - [Check for Updates...].
--	---

■ Others

No response.	<ul style="list-style-type: none"> ● Press  button to open Task Manager and close the software application that is not responding. ● An input screen (e.g., password input screen at startup) may be hidden behind another window. Press Alt+Tab to check. ● Press the power switch for 4 seconds or longer to shut down the computer, and then press the power switch to turn it on. If the application program does not work normally, uninstall and reinstall the program. To uninstall, <ol style="list-style-type: none"> ① Open the Control Panel. <ul style="list-style-type: none"> Windows 8.1 Flick from the middle of the Start screen to the top, and then touch [Control Panel] under “Windows System”. Windows 7 Touch  (Start) - [Control Panel] ② Touch [Programs] - [Uninstall a program].
--------------	---

LIMITED USE LICENSE AGREEMENT

THE SOFTWARE PROGRAM(S) (“PROGRAMS”) FURNISHED WITH THIS PANASONIC PRODUCT (“PRODUCT”) ARE LICENSED ONLY TO THE END-USER (“YOU”), AND MAY BE USED BY YOU ONLY IN ACCORDANCE WITH THE LICENSE TERMS DESCRIBED BELOW. YOUR USE OF THE PROGRAMS SHALL BE CONCLUSIVELY DEEMED TO CONSTITUTE YOUR ACCEPTANCE OF THE TERMS OF THIS LICENSE.

Panasonic Corporation has developed or otherwise obtained the Programs and hereby licenses their use to you. You assume sole responsibility for the selection of the Product (including the associated Programs) to achieve your intended results, and for the installation, use and results obtained therefrom.

LICENSE

- A. Panasonic Corporation hereby grants you a personal, non-transferable and non-exclusive right and license to use the Programs in accordance with the terms and conditions stated in this Agreement. You acknowledge that you are receiving only a LIMITED LICENSE TO USE the Programs and related documentation and that you shall obtain no title, ownership nor any other rights in or to the Programs and related documentation nor in or to the algorithms, concepts, designs and ideas represented by or incorporated in the Programs and related documentation, all of which title, ownership and rights shall remain with Panasonic Corporation or its suppliers.
- B. You may use the Programs only on the single Product which was accompanied by the Programs.
- C. You and your employees and agents are required to protect the confidentiality of the Programs. You may not distribute or otherwise make the Programs or related documentation available to any third party, by time-sharing or otherwise, without the prior written consent of Panasonic Corporation.
- D. You may not copy or reproduce, or permit to be copied or reproduced, the Programs or related documentation for any purpose, except that you may make one (1) copy of the Programs for backup purposes only in support of your use of the Programs on the single Product which was accompanied by the Programs. You shall not modify, or attempt to modify, the Programs.
- E. You may transfer the Programs and license them to another party only in connection with your transfer of the single Product which was accompanied by the Programs to such other party. At the time of such a transfer, you must also transfer all copies, whether in printed or machine readable form, of every Program, and the related documentation, to the same party or destroy any such copies not so transferred.
- F. You may not remove any copyright, trademark or other notice or product identification from the Programs and you must reproduce and include any such notice or product identification on any copy of any Program.

YOU MAY NOT REVERSE ASSEMBLE, REVERSE COMPILE, OR MECHANICALLY OR ELECTRONICALLY TRACE THE PROGRAMS, OR ANY COPY THEREOF, IN WHOLE OR IN PART.

YOU MAY NOT USE, COPY, MODIFY, ALTER, OR TRANSFER THE PROGRAMS OR ANY COPY THEREOF, IN WHOLE OR IN PART, EXCEPT AS EXPRESSLY PROVIDED IN THE LICENSE.

IF YOU TRANSFER POSSESSION OF ANY COPY OF ANY PROGRAM TO ANOTHER PARTY, EXCEPT AS PERMITTED IN PARAGRAPH E ABOVE, YOUR LICENSE IS AUTOMATICALLY TERMINATED.

TERM

This license is effective only for so long as you own or lease the Product, unless earlier terminated. You may terminate this license at any time by destroying, at your expense, the Programs and related documentation together with all copies thereof in any form. This license will also terminate effective immediately upon occurrence of the conditions thereof set forth elsewhere in this Agreement, or if you fail to comply with any term or condition contained herein. Upon any such termination, you agree to destroy, at your expense, the Programs and related documentation together with all copies thereof in any form.

YOU ACKNOWLEDGE THAT YOU HAVE READ THIS AGREEMENT, UNDERSTAND IT AND AGREE TO BE BOUND BY ITS TERMS AND CONDITIONS. YOU FURTHER AGREE THAT IT IS THE COMPLETE AND EXCLUSIVE STATEMENT OF THE AGREEMENT BETWEEN US, WHICH SUPERSEDES ANY PROPOSAL OR PRIOR AGREEMENT, ORAL OR WRITTEN, AND ANY OTHER COMMUNICATIONS BETWEEN US, RELATING TO THE SUBJECT MATTER OF THIS AGREEMENT.

Specifications

This page provides the specifications for the basic model. The model number is different according to the unit configuration.

- To check the model number:
Check the bottom of the computer or the box the computer came in at the time of purchase.
- To check CPU speed, memory size and the hard disk drive (HDD) size:
Run the Setup Utility (→  *Reference Manual* "Setup Utility") and select [Information] menu.
[Processor Speed]: CPU speed, [Memory Size]: Memory size, [Hard Disk]: Hard disk drive size

■ Main Specifications

Model No.	CF-D1GS Series	
CPU	Intel® Core™ i5-3340M Processor (3 MB ^{*1} cache, up to 3.40 GHz with Intel® Turbo Boost Technology)	
Chip Set	Mobile Intel® 7 QM77 Express Chipset	
Video controller	Intel® HD Graphics 4000 (Built-in CPU)	
Main Memory ^{*2}	4 GB ^{*1} , DDR3L SDRAM (8 GB ^{*1} Max.)	
Video Memory ^{*3}	Windows 8.1 UMA 1792 MB ^{*1} Max. Windows 7 UMA <32-bit> 1416 MB ^{*1} Max., <64-bit> 1696 MB ^{*1} Max.	
Storage	Hard Disk Drive: 500 GB ^{*4} (Serial ATA) Windows 8.1 Approx. 15 GB ^{*45} is used as a partition with HDD recovery tools. (Users cannot use this partition.) Approx. 1 GB ^{*45} is used as a partition with system tools. (Users cannot use this partition.) Windows 7 Approx. 50 GB ^{*45} is used as a partition with recovery tools. (Users cannot use this partition.) Approx. 300 MB ^{*45} is used as a partition with system tools. (Users cannot use this partition.)	
Display Method	13.3 type with Touchscreen (TFT) (1366 × 768 dots) (16:9)	
Internal LCD	65,536/16,777,216 colors (800 × 600 dots (Windows 7) / 1024 × 768 dots / 1280 × 720 dots / 1280 × 768 dots / 1360 × 768 dots / 1366 × 768 dots) ^{*6}	
	65,536 / 16,777,216 colors (800 × 600 dots (Windows 7) / 1024 × 768 dots / 1280 × 768 dots / 1366 × 768 dots / 1600 × 1200 dots / 1920 × 1080 dots / 1920 × 1200 dots)	
External Display ^{*7}		
Touchscreen	Resistive Circular Polarizer	
Wireless LAN	Intel® Centrino® Advanced - N 6235 (→ page 25)	
Bluetooth ^{*8}	→ page 26	
Wireless WAN ^{*9}	Equipped	
LAN	IEEE 802.3 10Base-T / IEEE 802.3u 100BASE-TX / IEEE 802.3ab 1000BASE-T (2nd LAN ^{*10} : IEEE 802.3 10BASE-T, IEEE 802.3u 100BASE-TX)	
Sound	WAVE and MIDI playback, Intel® High Definition Audio subsystem support	
Security Chip	TPM (TCG V1.2 compliant) ^{*11}	
Card Slots	PC Card Slot ^{*12}	× 1, Type I or Type II, Allowable current 3.3 V: 400 mA, 5 V: 400 mA
	ExpressCard Slot	× 1, ExpressCard/34 or ExpressCard/54
	SD Memory Card Slot ^{*13}	× 1
	Contact Smart Card Slot ^{*14}	× 1
	SIM Card Slot ^{*9}	× 1
RAM Module Slot	× 2, DDR3L SDRAM, 204-pin, 1.35 V, SO-DIMM, PC3L-10600 Compliant	
Interface	USB2.0 Ports ^{*15} × 2 or × 3 ^{*16} / USB3.0 Port × 1 / Serial Port (Dsub 9-pin male) ^{*17} / LAN Port (RJ-45) × 1 or × 2 ^{*10} / VGA Port (Mini DSub 15-pin female) ^{*18} / Microphone Jack (Miniature jack, 3.5 DIA) / Headphone Jack (Miniature jack, 3.5 DIA, Impedance 32 Ω, Output Power 4 mW × 2, Stereo) / Expansion Bus Connector (Dedicated 100-pin female) / Rugged USB2.0 Port ^{*15*19}	
Pointing Device	Touchscreen	
Button	Security, Application × 3, Function, A0	
Rear Camera ^{*20}	1280 x 720 dots, 30 fps (Video) / 2592 x 1944 dots (Still)	

■ Main Specifications

Model No.	CF-D1GS Series		
Power Supply	AC adaptor or Battery pack		
AC Adaptor ^{*21}	Input: 100 V to 240 V AC, 50 Hz/60 Hz, Output: 15.6 V DC, 7.05 A		
Battery Pack	Li-ion 10.8 V, Typical 6200 mAh / Minimum 5800 mAh		
Operating Time ^{*22}	Approx. 9.0 hours (Normal Temperature Mode)		
	Approx. 7.0 hours (High Temperature Mode)		
Charging Time ^{*23}	Approx. 2.0 hours (Normal Temperature Mode: in the OFF state)		
	Approx. 2.5 hours (Normal Temperature Mode: in the ON state)		
	Approx. 3.5 hours (High Temperature Mode)		
Power Consumption ^{*24}	Approx. 45 W ^{*25} / Approx. 100 W (maximum when recharging in the ON state)		
Physical Dimensions (W × D × H) (excluding projecting parts)	Approx. 349 mm × 244 mm × 46 mm {Approx. 13.7 " × 9.6 " × 1.8 "}		
Weight	Approx. 2.25 kg {Approx. 4.96 lb.}		
Environment	Operating	Temperature	-10 °C to 50 °C {14 °F to 122 °F} (IEC60068-2-1, 2) ^{*26}
		Humidity	30 % to 80 % RH (No condensation)
	Storage	Temperature	-20 °C to 60 °C {-4 °F to 140 °F}
		Humidity	30 % to 90 % RH (No condensation)

■ Software

Base OS	Windows® 8.1 Pro 64-bit
Installed OS ^{*27}	<p>Windows 8.1</p> <p>Windows® 8.1 Pro 64-bit</p> <p>Windows 7</p> <p><Only for Windows 7 downgrade model></p> <p>Windows® 7 Professional 32-bit Service Pack 1^{*28} / Windows® 7 Professional 64-bit Service Pack 1^{*28}</p>
Pre-installed Software ^{*27}	<p>Adobe Reader, PC Information Viewer, Intel® PROSet/Wireless Software, Battery Recalibration Utility, Infineon TPM Professional Package^{*11*29}, Camera Utility^{*20}, Camera Light Switch Utility^{*20}, Dashboard for Panasonic PC, Display Rotation Tool, Tablet Button Manager, Manual Selector, Power Plan Extension Utility, Hand Writing Utility, Recovery Disc Creation Utility, Microsoft Office Trial^{*30}</p> <p>Windows 8.1</p> <p>Wireless Toolbox, Camera for Panasonic PC, Intel® PROSet/Wireless Software for Bluetooth Technology</p> <p>Windows 7</p> <p>Wireless Switch Utility, Wireless Connection Disable Utility^{*29}, Quick Boot Manager, Software Keyboard, Bluetooth Stack for Windows by TOSHIBA</p> <p>Aptio Setup Utility, Hard Disk Data Erase Utility^{*31}, PC Diagnostic Utility</p>

■ Wireless LAN

Data Transfer Rates	<p>IEEE802.11a : 54/48/36/24/18/12/9/6 Mbps (automatically switched)^{*32}</p> <p>IEEE802.11b : 11/5.5/2/1 Mbps (automatically switched)^{*32}</p> <p>IEEE802.11g : 54/48/36/24/18/12/9/6 Mbps (automatically switched)^{*32}</p> <p>IEEE802.11n^{*33} : (HT20) GI^{*34} = 400ns: 150/130/115/86/72/65/57/43/28/21/14/7 Mbps (automatically switched)^{*32}</p> <p style="padding-left: 100px;">GI^{*34} = 800ns: 130/117/104/78/65/58/52/39/26/19/13/6 Mbps (automatically switched)^{*32}</p> <p style="padding-left: 100px;">(HT40) GI^{*34} = 400ns: 300/270/240/180/150/135/120/90/60/45/30/15 Mbps (automatically switched)^{*32}</p> <p style="padding-left: 100px;">GI^{*34} = 800ns: 270/243/216/162/135/121/108/81/54/40/27/13 Mbps (automatically switched)^{*32}</p>
Standards Supported	IEEE802.11a / IEEE802.11b / IEEE802.11g / IEEE802.11n
Transmission method	OFDM system, DSSS system

Specifications

■ Bluetooth

Bluetooth Version	4.0 Classic mode / Low Energy mode
Transmission method	FHSS system
Wireless Channels Used	Channels 1 to 79 / Channels 0 to 39
RF Frequency Band	2.402 GHz - 2.480 GHz

*1 1 MB = 1,048,576 bytes / 1 GB = 1,073,741,824 bytes

*2 Memory size of the factory default depends on the model.

You can physically expand the memory up to 8 GB, but the total amount of usable memory available will be less depending on the actual system configuration.

*3 A segment of the main memory is allotted automatically depending on the computer's operating status. The size of the Video Memory cannot be set by the user. The size of Video memory is allotted depending on the operating system.

*4 1 GB = 1,000,000,000 bytes. Your operating system or some application software will report as fewer GB.

*5 For MUI OS model.

*6 A 16,777,216 color display is achieved by using the dithering function.

*7 Display may be impossible using some connected external displays.

*8 Does not guarantee operation of all Bluetooth peripherals.

*9 Only for model with wireless WAN. The specification may differ depending on models.

*10 Only for model with 2nd LAN.

*11 Only for model with TPM. For information on TPM, **Windows 8.1** on the Start screen, touch the [Manual Selector] tile, and select "Installation Manual for Trusted Platform Module (TPM)" / **Windows 7** Double-touch [Manual Selector] on the desktop, and select "Installation Manual for Trusted Platform Module (TPM)".

*12 Only for model with PC Card slot.

*13 This slot is compatible with High-Speed Mode. Operation has been tested and confirmed using Panasonic SD/SDHC/SDXC Memory Cards with a capacity of up to 64 GB. Operation on other SD equipment is not guaranteed.

*14 Only for model with Smart Card slot.

*15 Does not guarantee operation of all USB-compatible peripherals.

*16 Only for model with 4th USB port (USB2.0).

*17 Only for model with serial port.

*18 Only for model with VGA port.

*19 Only for model with rugged USB2.0 port.

*20 Only for model with rear camera.

Depending on the specification of application software, the following cases may occur. In these cases, select a smaller resolution.

- Cannot select a large resolution.
- When selecting a large resolution, an error occurs.

*21 <Only for North America>

The AC adaptor is compatible with power sources up to 240 V AC adaptor. This computer is supplied with a 125 V AC compatible AC cord.

20-M-1

*22 Measured with LCD brightness : 60 cd/m²

Varies depending on the usage conditions, or when an optional device is attached.

*23 Varies depending on the usage conditions, CPU speed, etc.

*24 Approx. 0.5 W when the battery pack is fully charged (or not being charged) and the computer is off.

<When using with 115 V AC>

Even when the AC adaptor is not connected to the computer, power is consumed (Max. 0.2 W) simply by having the AC adaptor plugged into an AC outlet.

<When using with 240 V AC>

Even when the AC adaptor is not connected to the computer, power is consumed (Max. 0.3 W) simply by having the AC adaptor plugged into an AC outlet.

*25 Rated power consumption. 23-E-1

*26 Do not expose the skin to this product when using the product in a hot or cold environment. (→ "Safety Precautions / Regulatory Information")

When using in hot or cold environment, some peripherals and battery pack may fail to work properly. Check the operation environment of the peripherals.

Using this product continuously in a hot environment will shorten the product life. Avoid use in these types of environments.

When using in low temperature environment, startup may become slow or battery operation time may become short.

The computer consumes power when the hard disk is warming up during startup. Therefore, if you are using battery power and the remaining power is low, the computer may not start up.

*27 Operations of this computer are not guaranteed except for the pre-installed OS and the OS which is installed by using the hard disk recovery and the recovery disc.

*28 This system is preinstalled with Windows® 7 Professional software and also comes with a license for Windows 8.1 Pro software. You may only use one version of the Windows software at a time. Switching between versions will require you to uninstall one version and install the other version.

*29 Must be installed before use.

*30 To continue using this software after the end of the trial, purchase a license by following the on-screen instructions.

*31 Perform on the recovery disc. **Windows 7** Alternatively perform on the Hard disk recovery.

*32 These are speeds specified in IEEE802.11a+b+g+n standards. Actual speeds may differ.

*33 Available when set to "WPA-PSK", "WPA2-PSK" or "none".

*34 Only available when HT40 enabled by the computer and access point which associated supports HT40.

Panasonic Corporation
Osaka, Japan

Panasonic System Communications Company of North America
Two Riverfront Plaza, Newark NJ 07102

Panasonic Canada Inc.
5770 Ambler Drive Mississauga, Ontario L4W 2T3

Importer's name & address pursuant to the EU legislation
Panasonic System Communications Company Europe, Panasonic Marketing Europe GmbH
Hagenauer Straße 43
65203 Wiesbaden
Germany

55-E-1

Web Site : <http://panasonic.net/>

パナソニック株式会社 IT プロダクツ事業部
〒 570-0021 大阪府守口市八雲東町一丁目 10 番 12 号